

Assembly Instructions

StowAway SB Swingaway Frame
With or Without Optional Ski Box
Models ST 022.95 and ST 026.3
(Rev. 0221)

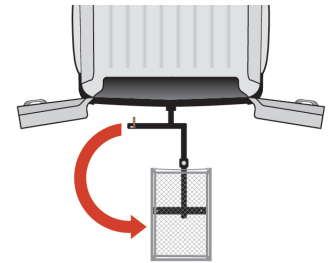

Thank you for purchasing this StowAway hitch carrier product and welcome to the StowAway Carrier family. Before assembling your frame and ski box please review the instructions and safety guidelines for the StowAway SB Swingaway Frame and Ski Box. Assembly and installation of the items are solely the end user's responsibility.

StowAway User Guidelines

- **EXHAUST WARNING** – Hot exhaust directed at or below the SB Swingaway frame could melt or damage items that you have mounted to the frame. For vehicles with straight back exhaust it is recommended that the exhaust be diverted with an exhaust pipe tip or deflected away from your contents with an exhaust shield. Exhaust shields are not necessary on vehicles with tail pipes that direct the exhaust downward or to the side of your contents.
- The SB Swingaway Frame is not intended for off-road use.
- SB Swingaway models should be used with a Class III or IV 2" receiver hitch. A seven-inch hitch extender can be used with Class III or IV hitches rated for more than 500 pounds tongue weight. Under no circumstances should the hitch tongue weight, vehicle tongue weight, or the gross vehicle weight be exceeded.
- Before driving, be sure that the SB Swingaway frame is latched, and both safeties are engaged. The frame should be regularly inspected for signs of wear, corrosion and/or fatigue.
- Rinse and lightly oil the SB Swingaway frame and hardware after traveling on salted roads or when using the frame in a salt air environment. Coating the inside and outside of the frame with a rust preventive product is advised in the case of regular exposure to salt or salt air.

Thank you for purchasing a StowAway Carrier product.

Please contact us with any questions.

Pacific Recreational Products, Inc.

7291 SW Tech Center Drive • Tigard, OR 97223

Phone: 800.943.5377 • Fax: 503.968.1433

E-mail: customerservice@StowAway2.com

StowAway2.com



Assembly Instructions



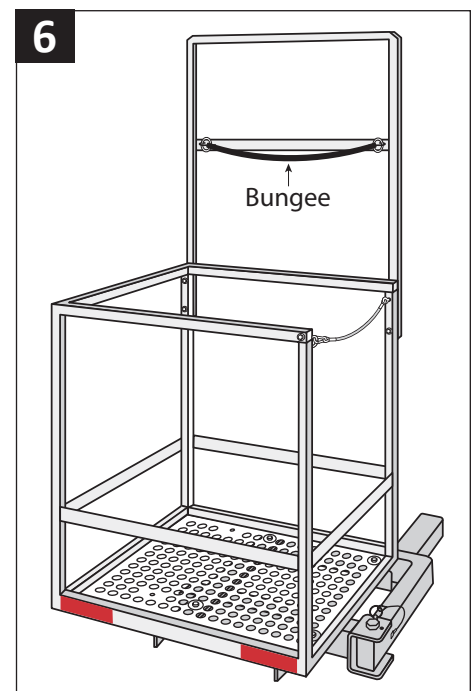
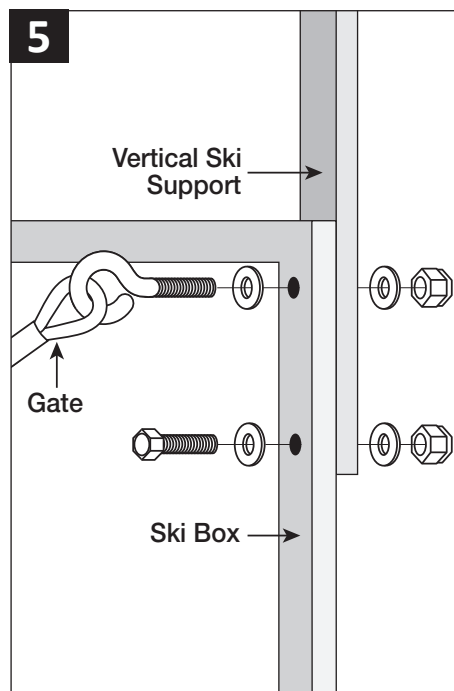
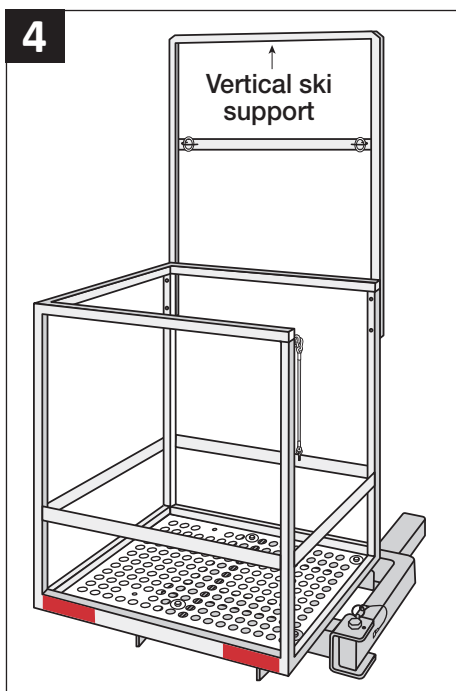
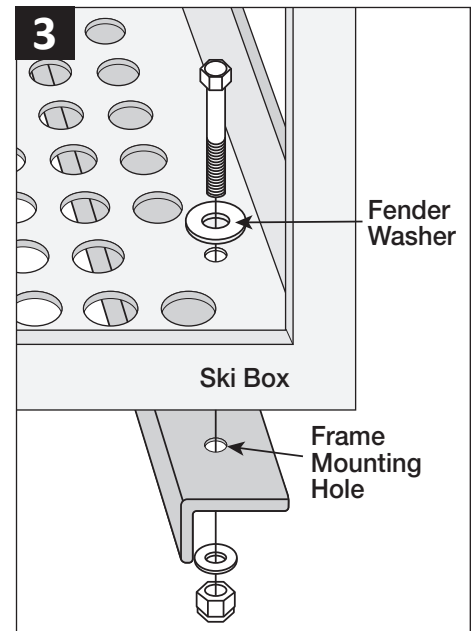
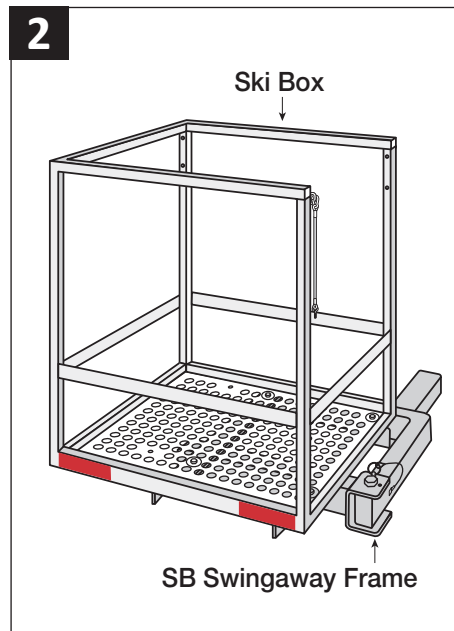
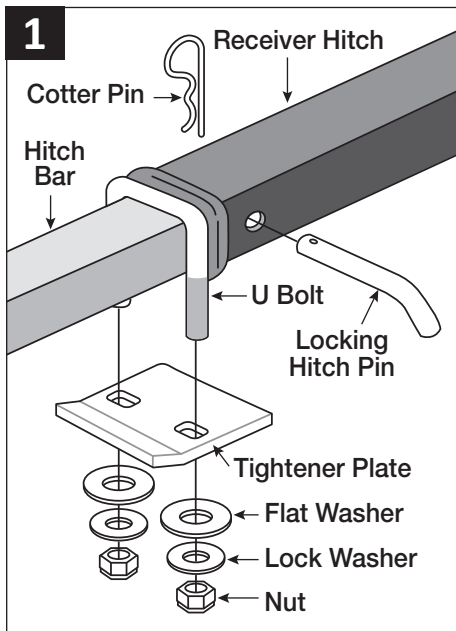



- Carefully remove all items from the shipping cartons. Check parts list on page 3.
- Your SB Swingaway frame should arrive pre-assembled. If it is not, please see instructions on page 3.
- Be sure the Swingaway frame is closed in the latched position. Slide frame into your hitch receiver and insert the hitch pin or hitch lock into one of the hitch pin holes. Add hitch tightener (**Figure 1**).
- Position the ski box on the frame with reflectors facing rearward (**Figure 2**). Bolt the ski box to the frame mounting holes, with washers on the topside and bottom side of the ski box base (**Figure 3**).
- Position the vertical ski support to the ski box (**Figure 4**) using the 5/16" bolts, eyebolt with gate, and nuts (**Figure 5**). Attach the rubber bungee cord to the eyebolts on the vertical ski support (**Figure 6**).

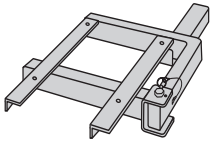

Using the SB Swingaway Frame

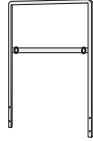
1. The SB SwingAway frame is equipped with a latch, a ball detent pin and a secondary safety. To close the frame, swing it closed until the latch engages. Insert the ball detent pin. Drop the secondary safety into place at the pivot point.
2. To open the frame, remove both safeties, pull up on the orange plunger pin and swing the frame open.
3. The SB SwingAway frame may be locked at 90 degrees from the vehicle by inserting the secondary safety pin into hole at the pivot point. Care should be taken when swinging the frame open near traffic or on an incline. Your gear should be loaded with the frame in the closed position if possible.

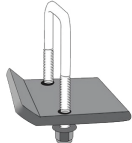
Parts List

SB Swingaway Frame	
Ski Box Enclosure	
Wire gate for enclosure	
Vertical Upright for Ski's	
Hitch Pin	
Hitch Tightener	
Bungee Cord	
Ski Box Hardware Kit	4 Mounting Bolts - 3/8" x 1 1/4" 4 Flat Fender Washers - 3/8" x 1.5" 4 Flat Washers - 3/8" 4 Nylon Lock Nuts - 3/8"
Vertical Upright Hardware Kit	1 Eyebolt with Gate 3 Bolts - 5/16" x 1" 8 Flat Washers - 5/16" 4 Nylon Lock Nuts - 5/16"

SB Swingaway Frame Assembly Instructions

If the SB Swingaway frame is not pre-assembled, slide the hitch bar section into the hitch and insert the hitch pin or hitch lock to anchor it. Position the swing arm and insert the pivot bolt with washers through the yoke to attach the swing arm. Add and tighten the pivot bolt nut, placing washers as shown. Note that the nut is a nylok nut and will tighten noticeably as it is turned onto the bolt.

